

Oil Tank - OTS544AR/53/B

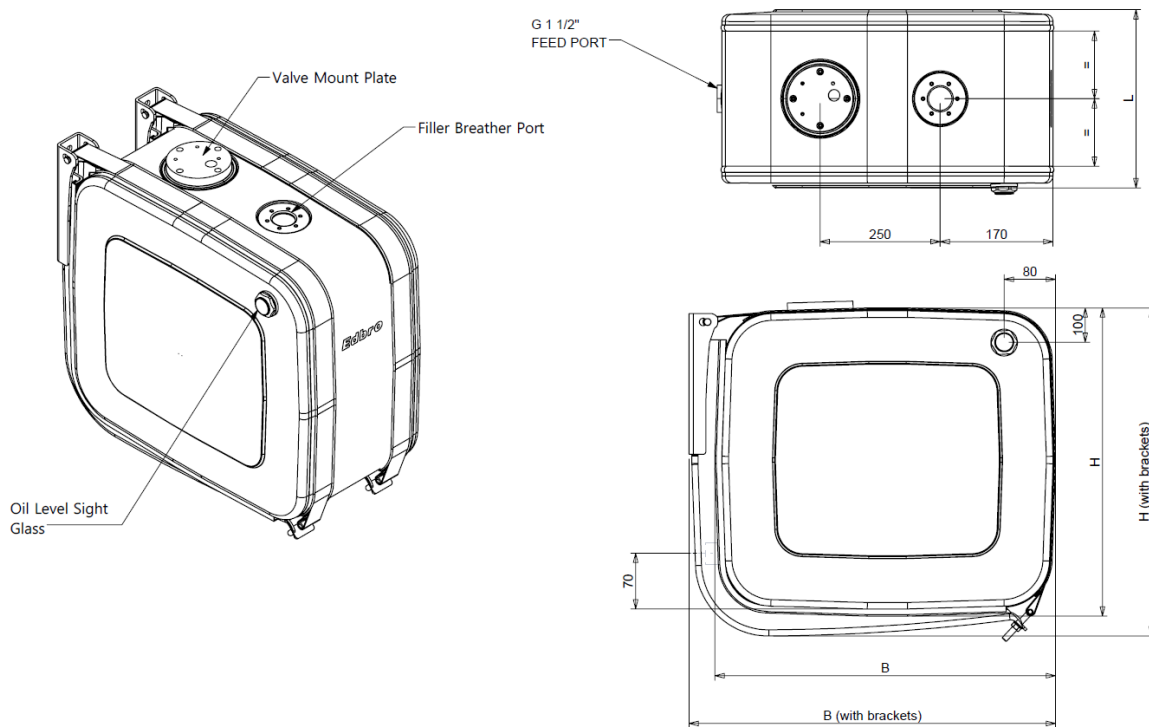

Highly polished aluminium finish
1.5" BSP Female Feed Port Port
for optional filter
UT Valve Plate

Universal bracket hole pattern
Pressure tested
Steel brackets with SS straps

Part Number	Dimensions (mm)			Total Capacity (Litres)	Useable Capacity (Litres)	Mass (Kg) (inc. kit)
	H	B	L			
OTS544AR/53/B	500	425	400	85	53	35Kg
(with brackets)	575	500	400			

NOTES

All tanks are optionally supplied with separate oil filler/air breather AF97 * Add 65mm for filler cap

Valve connection :

Optional Filters

Part Ref.	Max Flow (L/min)	Filtration (μ m)	Connection
PM643	200	60	G1"
PM642	160	25	G1"
PM476	200	25	G1"
PM627	200	25	G 1.1/4"

Tank Selection:

Select a tank that has a useable capacity greater than the swept volume of the cylinder/working volume of the application.

Tank Capacity:

Total capacity is the amount of oil to fill the tank and leave 90mm air gap above the oil. Useable capacity is calculated assuming:

A minimum of 100mm oil depth left at the bottom of the tank the tank when empty and an air gap of 90mm above the oil when the tank is full.