

SECTION A-A

Both plates and CHS to be fully welded to main plate at the front

No weld required around the tube at the rear of the plate.

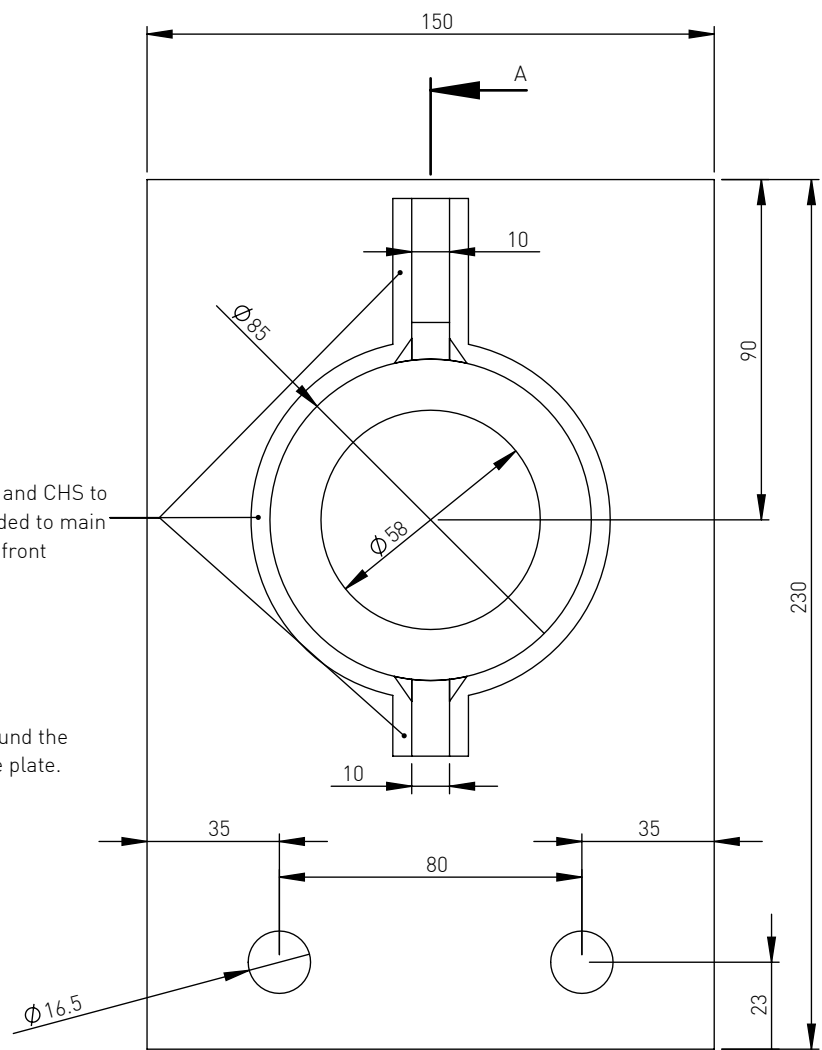

**01** Front Elevation  
 Scale 1:2

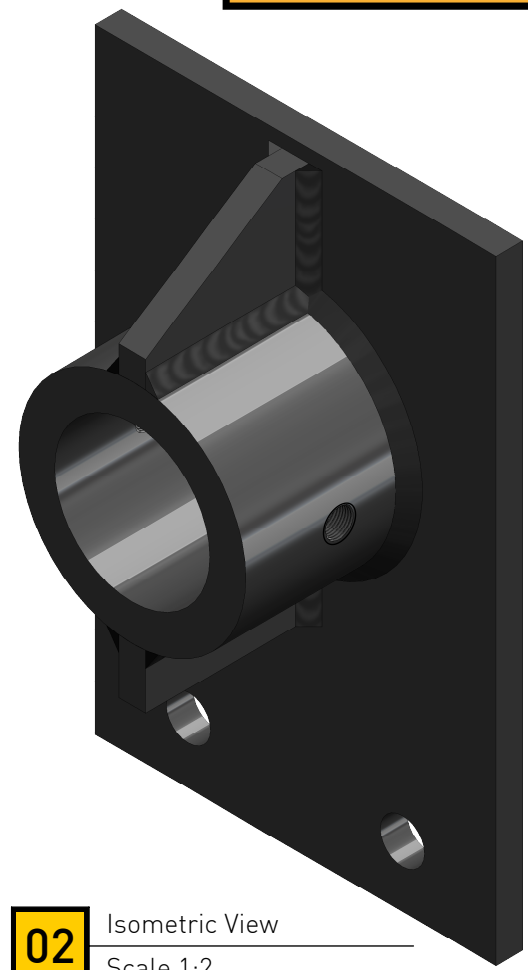

**02** Isometric View  
 Scale 1:2

Rev	Description	Date