



0-467-21 - 20VDC Li-Ion Brushless Impact Screwdriver Quick Connect 10mm (1/4") Drive + 4.0Ah Battery + UK Fast Charger in a BMC



Durite Cordless Impact Screwdriver with quick connect 10mm (1/4") drive in a BMC. 20.0V 1/4" Brushless Impact Screwdriver (0-467-22) with 4.0Ah Lithium Ion Battery (0-467-42) and UK 3 PIN Charger (0-467-43) Supplied in a BMC. No Load Speed 0-900 / 0-2000 / 0-2800rpm. Impact Rate 0-3200min. MaxTorque 200Nm. CE UKCA RoHS.

THE TRUSTED QUALITY BRAND FOR PROFESSIONALS



Warning / Danger!

Read manual before use. In accordance with essential applicable safety standards of UK and European directives.

	Warning / Danger!
	Read manual before use.
	In accordance with essential applicable safety standards of European + UK directives.

Read all safety warnings and all instructions. Failure to follow all warnings and instructions may result in electric shock, fire and/or serious injury. Save all warnings and instructions for future reference. The term “power tool” in the warnings refers to your mains operated (corded) power tool or battery operated (cordless) power tool.

Work Area

- Keep work area clean and well lit. Cluttered and dark areas invite accidents.
- Do not operate power tools in explosive atmospheres, such as in the presence of flammable liquids, gases or dust. Power tools create sparks which may ignite the dust or fumes.
- Keep children and bystanders away while operating a power tool. Distractions can cause you to lose control.



Electrical Safety

Always check that the power supply corresponds to the voltage on the rating plate.

- Power tool plugs must match the outlet. Never modify the plug in any way. Do not use any adapter plugs with earthed (grounded) power tools. Unmodified plugs and matching outlets will reduce risk of electric shock.
- Avoid body contact with earthed or grounded surfaces such as pipes, radiators, ranges and refrigerators. There is an increased risk of electric shock if your body is earthed or grounded.
- Do not expose power tools to rain or wet conditions. Water entering a power tool will increase the risk of electric shock.
- Do not abuse the cord. Never use the cord for carrying, pulling or unplugging the power tool. Keep cord away from heat, oil, sharp edges or moving parts. Damaged or entangled cords increase the risk of electric shock.
- When operating a power tool outdoors, use an extension cord suitable for outdoor use. Use of a cord suitable for outdoor use reduces the risk of electric shock.
- If operating a power tool in a damp location is unavoidable, use a residual current device (RCD) protected supply. Use of an RCD reduces the risk of electric shock.

Personal Safety

- Stay alert, watch what you are doing and use common sense when operating a power tool. Do not use a power tool while you are tired or under the influence of drugs, alcohol or medication. A moment of inattention while operating power tools may result in serious personal injury.
- Use safety equipment. Always wear eye protection. Safety equipment such as dust mask, non-skid safety shoes, hard hat, or hearing protection used whenever conditions require will reduce personal injuries.
- Avoid accidental starting. Ensure the switch is in the off position before plugging in.
- Carrying power tools with your finger on the switch or plugging in power tools that have the switch on invites accidents.
- Remove any adjusting key or wrench before turning the power tool on. A wrench or a key left attached to a rotating part of the power tool may result in personal injury.
- Do not overreach. Keep proper footing and balance at all times. This enables better control of the power tool in unexpected situations.
- Dress properly. Do not wear loose clothing or jewellery. Keep your hair, clothing and gloves away from moving parts. Loose clothes, jewellery or long hair can be caught in moving parts.
- If devices are provided for the connection of dust extraction and collection facilities, ensure these are connected and properly used. Use of these devices can reduce dust related hazards.

Power Tool Use & Care

- Do not force the power tool. Use the correct power tool for your application. The correct power tool will do the job better and safer at the rate for which it was designed.
- Do not use the power tool if the switch does not turn it on and off. Any power tool that cannot be controlled with the switch is dangerous and must be repaired.
- Disconnect the plug from the power source before making any adjustments, changing accessories, or storing power tools. Such preventive safety measures reduce the risk of starting the power tool accidentally.
- Store idle power tools out of the reach of children and do not allow persons unfamiliar with the power tool or these instructions to operate the power tool. Power tools are dangerous in the hands of untrained users.
- Maintain power tools. Check for misalignment or sticking of moving parts, breakage of parts and any other condition that may affect the power tool's operation. If damaged, have the power tool repaired before use. Many accidents are caused by poorly maintained power tools.
- Keep cutting tools sharp and clean. Properly maintained cutting tools with sharp cutting edges are less likely to stick and are easier to control.
- Use the power tool, accessories and tool bits etc., in accordance with these instructions and in the manner intended for the particular type of power tool, taking into account the working conditions and the work to be performed. Use of the power tool for operations different from intended could lead to a hazardous situation.

Charging / Batteries

- Charge battery only with the charger that is supplied with the tool
- Do not touch the contacts in the charger
- Do not expose tool/charger/battery to rain
- Do not charge battery in damp or wet environments

Store tool/charger/battery in locations where temperature will not exceed 50°C or drop below 0°C

- Do not use charger when damaged.
- Do not use charger when cord or plug is damaged.
- Do not use battery when damaged; it should be replaced immediately
- Do not disassemble charger or battery
- Do not attempt to recharge non-rechargeable batteries with the charger
- If you anticipate long periods of non-use for the tool, it is best to unplug the charger from its power source

WHEN CONNECTING NEW 3-PIN PLUG (U.K. ONLY):

- Do not connect the blue(= neutral) or brown(= live) wire in the cord of the charger to the earth terminal of the plug
- If for any reason the old plug is cut off the cord of the charger, it must be disposed of safely and not left unattended

Service

- Have your power tool serviced by a qualified repair person using only identical replacement parts. This will ensure that the safety of the power tool is maintained.

Cleaning and Maintenance

When not in use, the tool should be stored in a dry, frost free location, out of reach of children. Keep ventilation slots of the tool clean at all times and prevent any foreign matter from entering. If the housing of the tool requires cleaning, do not use solvents but a moist soft cloth only. Blow out the ventilation slots with compressed air periodically.

End Of Life Disposal - in Accordance with WEEE Directive EU 2012/19/EU



Should your appliance need replacement after use, do not discard it with the household rubbish but dispose of it in an environmentally safe way.

Waste produced by electrical machine items should not be handled like normal household rubbish. Please recycle where recycle facilities exist. Check with your Local Authority or retailer for recycling advice.

Image 1: Product Schematic

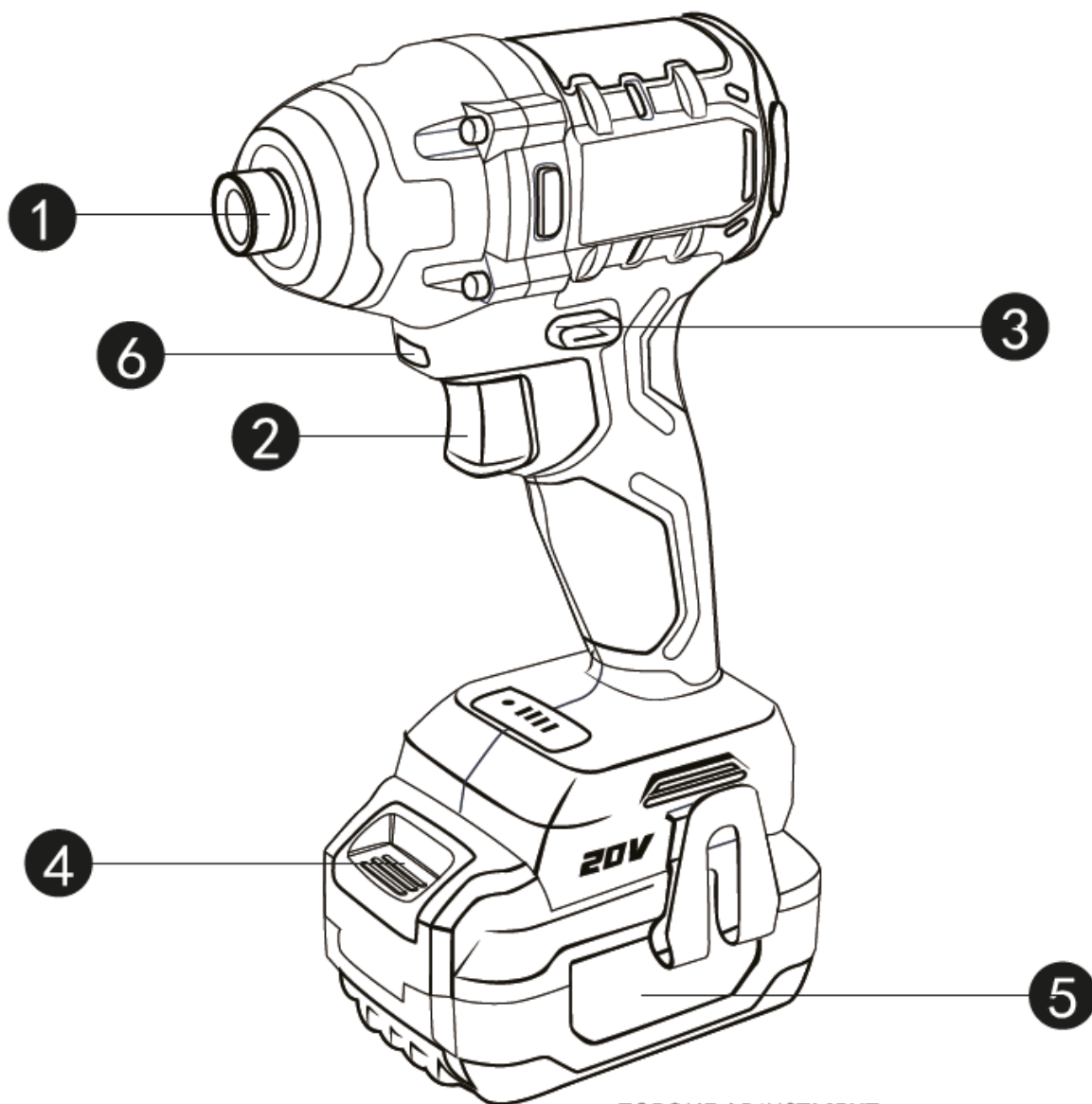

- 1. Keyless chuck
- 2. Trigger
- 3. Forward/Reverse selector
- 4. Battery release button
- 5. Battery pack
- 6. Worklight

TORQUE ADJUSTMENT

- a. First setting: Exquisite operation
- b. Second setting: Moderate power to avoid damage to the workpiece
- c. Third setting: Release Max Torque and power
- d. Fourth setting: Intelligence adjust control

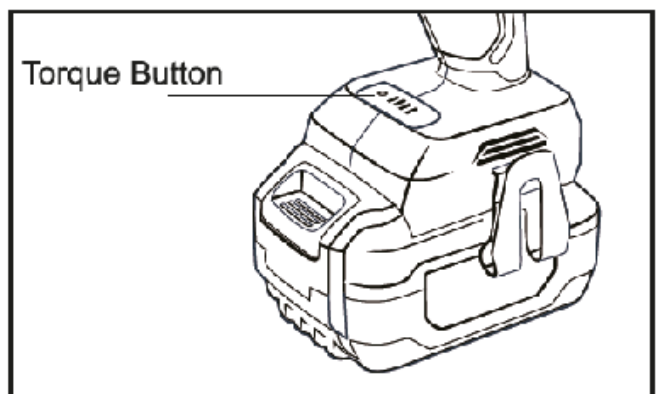

Operation

Always switch off the tool before insertion or removal of the battery. Installing the battery holding the tool upright and picking up the battery in your opposite hand, push the battery release button and insert the battery until it clicks into place. Do not use excessive force when inserting the battery, if the battery does not slide in easily, it is not being inserted correctly, it is also possible that there could be damage to the battery, battery terminals or the tool.

Changing the Direction of Rotation: (Please see overleaf Image 1 product schematic for further detail)

The direction of rotation can be changed with the forward/release selector, this is located above the variable speed switch. To select the forward position, push the forward/reverse selector hard left. To select the reverse position, push the forward/reverse selector hard right. Do not change the direction of rotation while the tool is in motion. To lock the tool put the selector in the centre position. This can also prevent accidental starting of the tool.

LED Lights:

The tool has 1 LED light built into the unit. The LED light is located above the variable speed switch. The LED light turns on automatically when you depress the variable speed switch. The LED light illuminates dark areas in tight corners to assist with the view of the workplace.

LED Power Indication:

3 LEDs will show you the capacity of battery.

Removing the Battery:

Depress the battery release button and gently pull the battery out of the tool.

Charging the battery:

The tool has been shipped in a quick charge condition. You should charge it prior to use. Plug the charger into a power outlet. Insert the battery into the charger. The recess of the battery terminals will have a firm connection. Upon proper contact the red and green light will illuminate and when fully charged the red light will go out and only the green light will be illuminated.

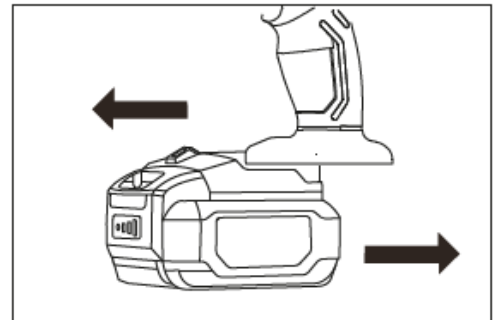

NOTE: If the charging light fails to come on:

- Check the charger is securely plugged into the wall outlet and is switched on.
- Check the battery is firmly seated onto the charger.

The battery will take 1 hour to charge. Charging starts automatically. Remove the battery from the charger once charged otherwise it may become damaged.

When the battery is hot, it may not charge immediately. This is a feature of the lithium ion battery as charging hot batteries shortens their life. In this case, the green light only will illuminate when the battery is inserted into the charger. The battery needs to cool which may take several minutes and it will automatically start charging once cooled.

Initial Charge :

Charge your battery for 1 hour then use it until it runs down and only slowly operates.

Repeat this charge and discharge process approximately 4-5 times, this will ensure that the battery is performing to its highest capacity. Charger will turn off when the battery is fully charged.

Important Charging Notes:

The charger and battery may become warm to touch while charging. This is a normal condition, and does not indicate a problem. Use the charger at normal room temperatures whenever possible. To prevent overheating, do not cover the charger and do not charge the battery in direct sunlight or near heat sources.

NOTE: If the battery does not charge properly:

- Check current at power outlet by plugging in a lamp or other appliance.
- If charging problems persist, have the complete tool checked by an electrician or a power tool repairer.





Battery:

The length of service from each charging cycle will depend on the type of work you are doing. The battery in this tool have been designed to provide maximum trouble free life. However, like all batteries, they will eventually wear out.

To obtain the longest possible battery life, we suggest the following: Store and charge your battery in a cool area. Temperatures above or below normal room temperature will shorten battery life.

Never store batteries in a discharged condition. Recharge them immediately after they are discharged. All batteries gradually lose their charge. The higher the temperature the quicker they lose their charge. If you store your tool for long periods of time without using it, recharge the batteries every month or two. This practice will prolong battery life.

Charger Diagnostics:

Description of LED display	Picture	Indicating Status	Charger Model
Steady red light		Charger is in plugged	2A/4A/6A
Steady red light + flashing green light		Battery is charging	2A/4A/6A
Steady red light + steady green light		Battery is fully charged	2A/4A/6A
Flashing red light		Battery pack is too hot	2A/4A/6A
Red and green light flashing alternatively		Battery pack is defective	2A/4A/6A

EC DECLARATION OF CONFORMITY

Durite Limited, at the address shown at the bottom of the page, hereby confirms that the following device:

0-467-22 - Impact Driver 1/4" 10mm Quick Socket Drive 20.0 volt 4.0Ah

0-467-42 - Battery Li-Ion 4.0Ah 20.0 volt for 0-467-40

0-467-43 - 230volt UK Battery Charger for 20volt Battery 0-467-42

Conforms to the following European Directives and are manufactured in accordance with the following standards or standardized document:

EN62841-1:2015

EN62841-2-2:2014

AFPS GS 2019:01 PAK

EK9-BE-91(V4):2020

The machinery directive (2006/42/EC)

BS EN 60335-2-29:2004 A11:2018

BS EN 60335-1:2012 A13:2017 BS EN 62233:2008

AFPS GS 2014:01 PAK

BS EN 62133-2

EN 55014-1:2017

EN55014-2:2015

EN61000-3-2:2014

EN61000-3-3:2013

The EMC directive:2014/30/EU

The technical documentation is kept at:

Durite Ltd, Valley Road, Dovercourt, Essex, CO12 4RX



Pierre Nadeau

Managing Director

06.08.2021

TECHNICAL SPECIFICATIONS

Motor Voltage	20.0V DC
Drive	10mm or 1/4" quick connect socket
Motor	#5010
Weight (Inc Bat)	1.875Kg
Weight (Ex Bat)	1.200Kg
No Load Speed	0-900 / 0-2000 / 0-2800rpm
Impact Rate	0-3200 IPM
Max Torque	200Nm
Vibration	K = 1,5M ² Ah= 11,64M ²
Battery Type	Lithium Ion
Battery	20.0V 4.0Ah
Battery Weight	0.675Kg
Charging Time	1 Hour
Approval	CE, UKCA, RoHS

TECHNICAL DRAWING

