

SPECIFICATION OF PURCHASED PARTS

Description				Partnumber		Revision	
OIL TANK 150 L SMALL FILTER 1 REAR 1 LOWER OUTLET				339-7037		1	
	Created By	Created Date	Standard		Material Description		
	JOL	2016-06-30					
	Modified By	Modified Date	Weight (kg)	Surface Treatment	Lifecycle State		
	IN-KP	2022-06-07	35.90	C 226.502	Released		

Sheet: 1/2

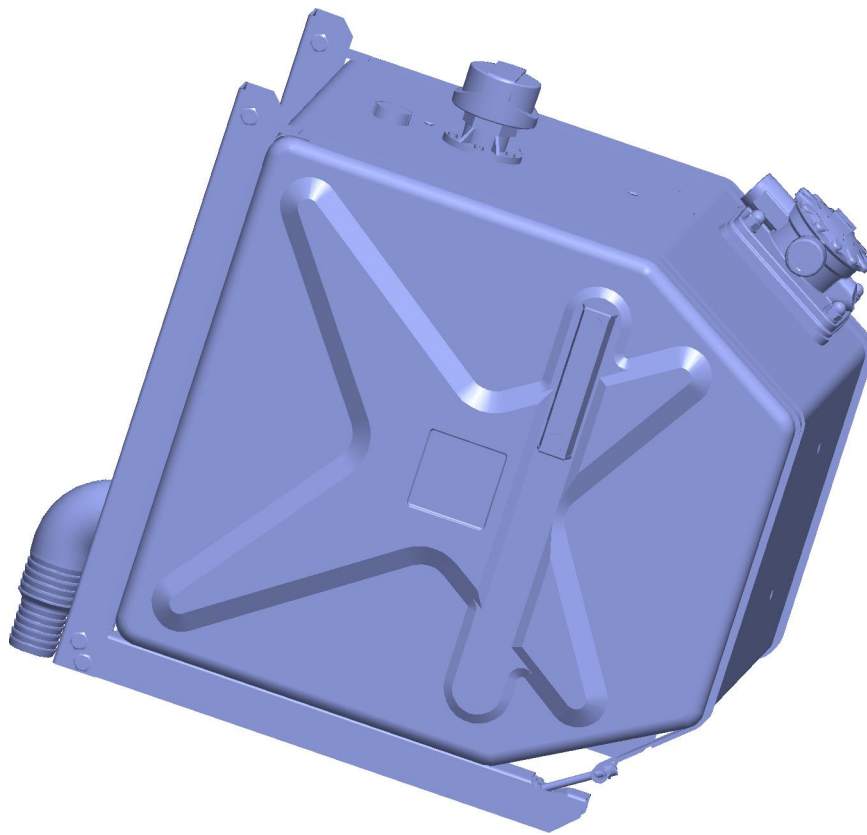

Model	150 Ltr smal filter
Return filter conection dim	ISO G1"
Suction outlett dim	2" and 2 1/2"

Rev.	Reason Change order	Date	Drawn Date	Appr. by	Check Appr. by
A	New Part	2018-02-24		JP	LO

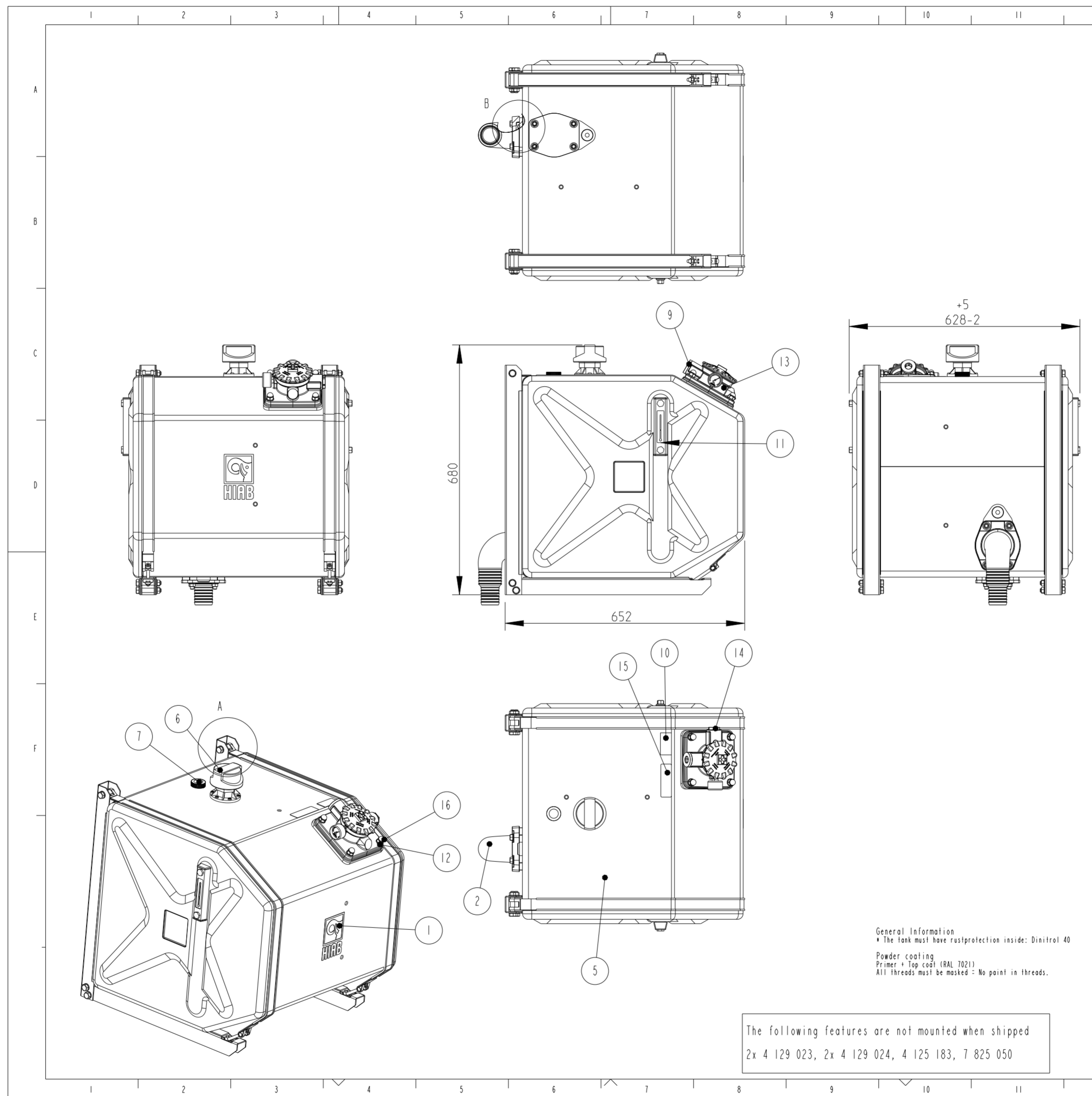

ITEM NO.	PART NUMBER	DESCRIPTION	QTY.
1	387 0363	Dekal HIAB Logga	1
2	4 125 183	BF Suganslutning 2.1/2 & 2" 90gr / BF Suction Connection 2.1/2" & 2" 90deg	1
3	4 129 023	Konsol komplett / Bracket complete	2
4	4 129 024	Spännband/Straps	2
5	4 129 027	Tank 150L GEN 2 LO	1
6	7 825 002	Andningsfilter, HIAB Logga / Breather HIAB Logo	1
7	7 825 003	Oljesticka 1" / Dipstick 1"	1
8	7 825 008	O-Ring	1
9	7 825 012	Stål-plugg 1" / Steel-plug 1" m O-ring	1
10	7 825 033	Märk dekal / Marking label	1
11	7 825 050	Nivåglas / Level gauge 127mm	1
12	7 825 070	Bricka / Washer 10,5x20x2 FZB	4
13	7 825 189	Filter litet / Small filter HIAB RFM195	1
14	7 825 231	Plastplugg / Plastic plug R1"	1
15	7 825 300	ID Skylt / ID Label	1
16	7 825 301	Kupolmutter / Dome nut M10 FZB - DIN 1587	4

General Information
 * The tank must have rustprotection inside: Dinitrol 40
 Powder coating
 Primer + Top coat (RAL 7021)
 All threads must be masked: No paint in threads.

The following features are not mounted when shipped
 2x 4 129 023, 2x 4 129 024, 4 125 183, 7 825 050

Drawing No. ISO 2000 Title Part No. Scale Date Drawn by Checked by Approved by	Drawing No. ISO 2000 Title Part No. Scale Date Drawn by Checked by Approved by	Material Surface Treatment Powderlock	Status Released Revision A Date 2018-02-24 Drawn by JP Checked by LO
---	---	---	---

This drawing is the property of HIAB Cranes and protected in accordance with prevailing law.

Pos	Ident	Qty	Description and Standard Dimension	Standard
Created By		Created Date	Scale	Material Description
Modified By		Modified Date	Weight (kg)	Surface Treatment
Description		Part Number	Revision	Lifecycle State
This product must be produced according to HIAB standard C1000		OIL TANK 150 L SMALL FILTER 1 REAR 1 LOWER OUTLET	339-7037	Released