

PRESA DI FORZA A COMANDO PNEUMATICO

PNEUMATIC CLUTCH POWER TAKE-OFF

CODICE PTO
PTO CODE

10-77-178

CAMBIO
GEARBOX

ZF



DIAGRAMMA DI UTILIZZO WORKING CONDITION



Presa di forza con uscita non supportata. È necessario l'utilizzo di pompe con albero supportato.
PTO with loose gear output. Mounting only possible with hydraulic pumps having bearing on the shaft.

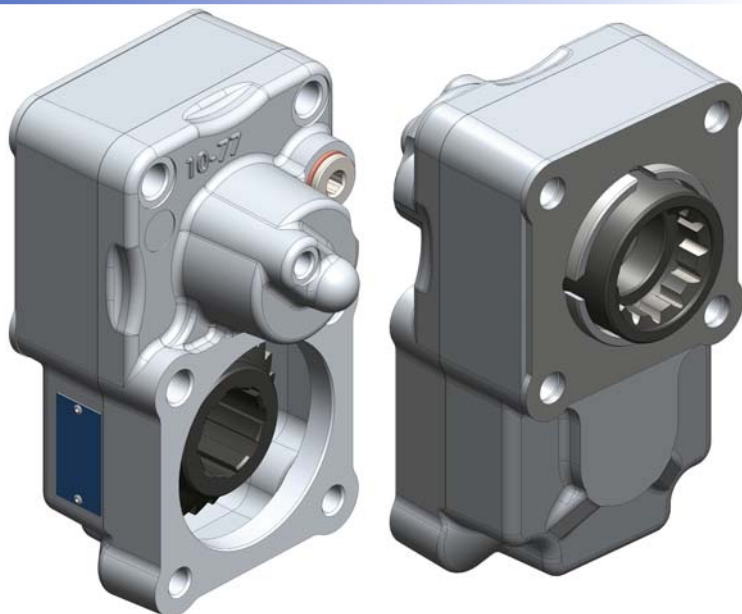
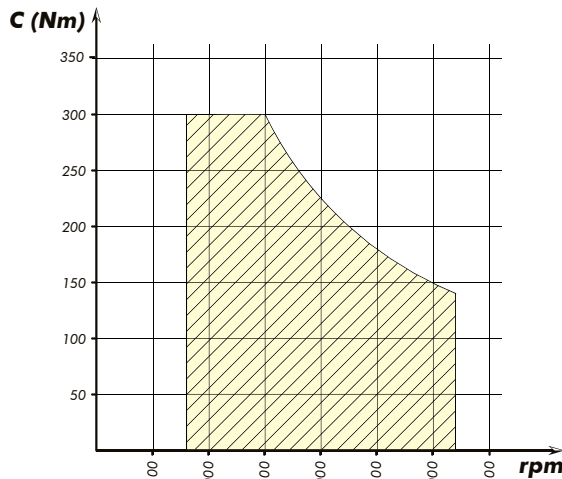
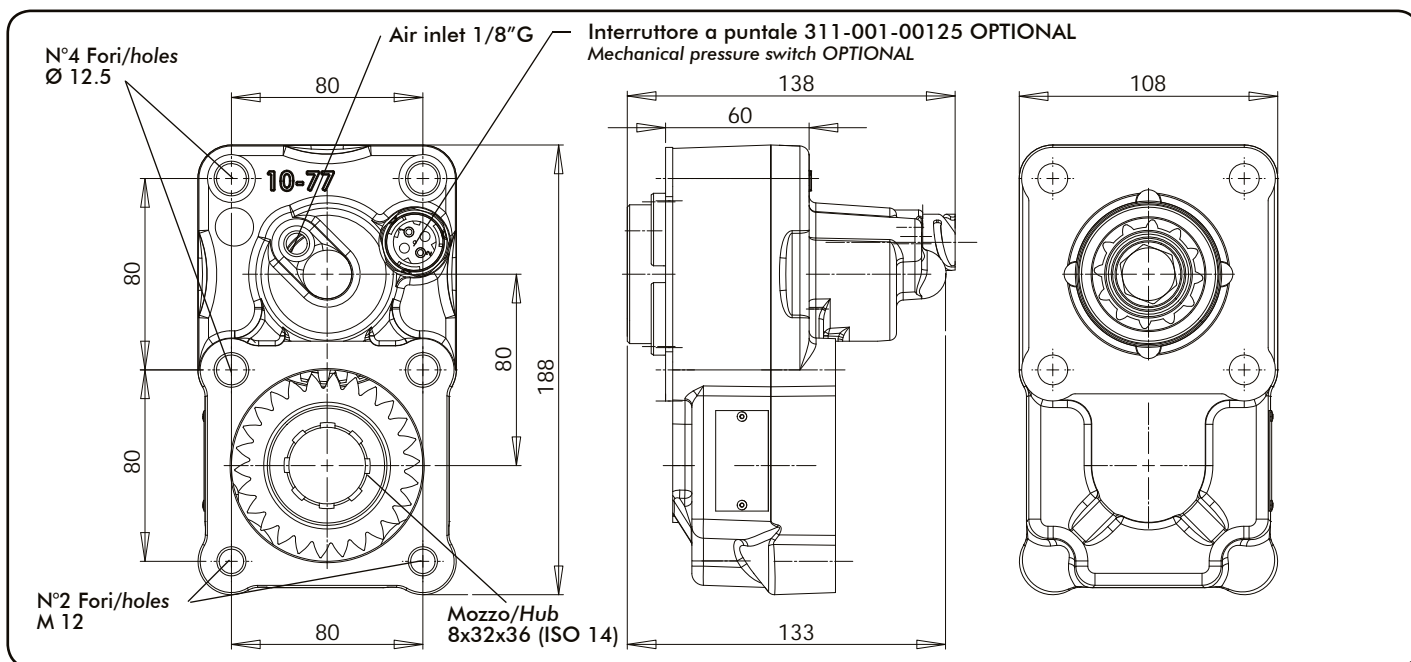

Tipo cambio Gearbox	Codice PTO PTO code	Versione Version	Giri pto a 1000 giri motore Pto ratio@1000 eng.rpm	Coppia massima Max torque	Lato montaggio Mounting side	Uscita Output	Rotazione Rotation	Kit di montaggio Mounting kit	Peso Weight
Vedi indice See index	10-77-00178	17	Vedi indice See index	300	Poster. Rear	Poster. Rear	Ant. Acw	Vedi indice See index	4,3

Rapporto interno / Internal ratio = 1:1.35

pag.1



O.M.F.B. S.p.A. Hydraulic Components
We reserve the right to make any changes without notice.
Edition 2009.10 No reproduction, however partial, is permitted.
Via Cave, 7/9 25050 Provaglio d'Iseo (Brescia) Italy Tel.: +39.030.9830611
Fax: +39.030.9839207-208 Internet:www.omfb.it e-mail:info@omfb.it

**COMPANY WITH
QUALITY SYSTEM
CERTIFIED BY DNV GL
= ISO 9001:2015 =**