

# HYVA CYLINDER



715 05 354

Front end cylinder with outer cover

type

FC 149-4-04940-000A-K0343

tipping weight

35-74 ton

page # 1 / 2

closed length (K)

338-373 mm

front & side view cylinder

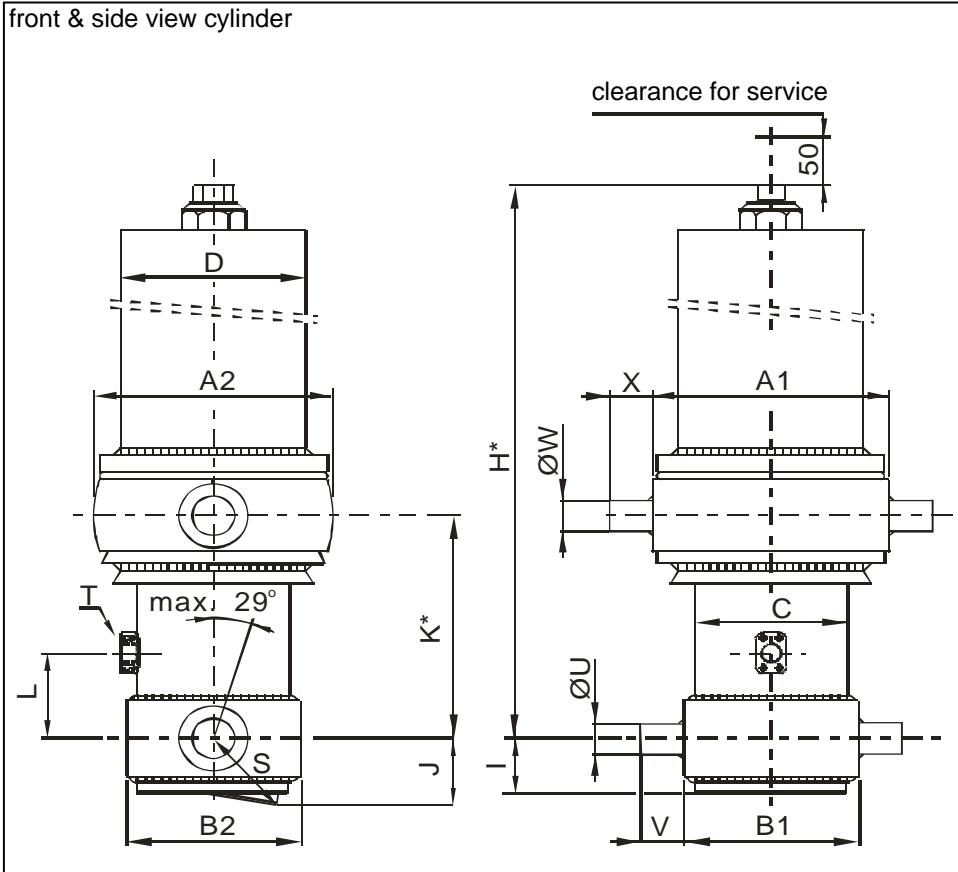

	1	2	
A	340	329	mm
B	201	201	mm
C	169		mm
D	242		mm
E			mm
F			mm
G*			mm
H*	1564		mm
I	60		mm
J	96		mm
K*	343		mm
L	190		mm
M*			mm
N			mm
O			mm
P			mm
Q			mm
R			mm
S	114		mm
T	1" SAE		
U	60		mm
V	65		mm
W	60		mm
X	65		mm
Y			mm
Z			mm

\*incl.20 [-5;+30] mm pull out on piston

## specifications

weight cylinder only	259 kg
total volume	63 L
working volume	58 L
maximum pressure	190 bar
maximum pump flow	137 L/min
maximum cylinder angle to front	10 °
maximum thrust first stage**	30 ton

\*\*when cyl. mounted at a large angle, thrust first stage may become too high: see Hyva Tipper Program

## technical notes

This cylinder is a lifting device only and may not be used as structural member or be subject to side load. Working pressure depends on application; never exceed maximum pressure. Cylinder painted with Akzo Air drying Enamel (RAL9005). Max duration of extension 2 hours (excluded HC). See mounting instruction CYL-0019. See oil specification sheet OIL-0002. See bracket specification sheet 015BRA01.

extension	1	2	3	4	5	6	7	8	9	
effective diameter [mm]	149	129	110	91						total
stroke [mm]	1220	1240	1240	1240						4940

## tipping weight

tipping weight at maximum pressure of 190 bar and C is 229 mm

BL (body length); OH (rear overhang); X=Ycog (vert. pos. centre of gravity); Qo (pivot length); C (bracket length); At = stroke x 60 / Qo	BL	6600			6250			5900		
	OH	200	500	800	200	500	800	200	500	800
	At	44	46	49	47	49	52	50	52	56
Ycog	600	35	38	43	36	40	46	38	43	50
900	37	42	48	39	45	53	42	49	60	
1200	40	46	54	43	50	62	47	57	74	

Subject to change without notice.

DO-E 715 05 354 / 08-02-27 / RV AD

# HYVA CYLINDER



715 05 354

Front end cylinder with outer cover

type

FC 149-4-04940-000A-K0343

page # 2 / 2

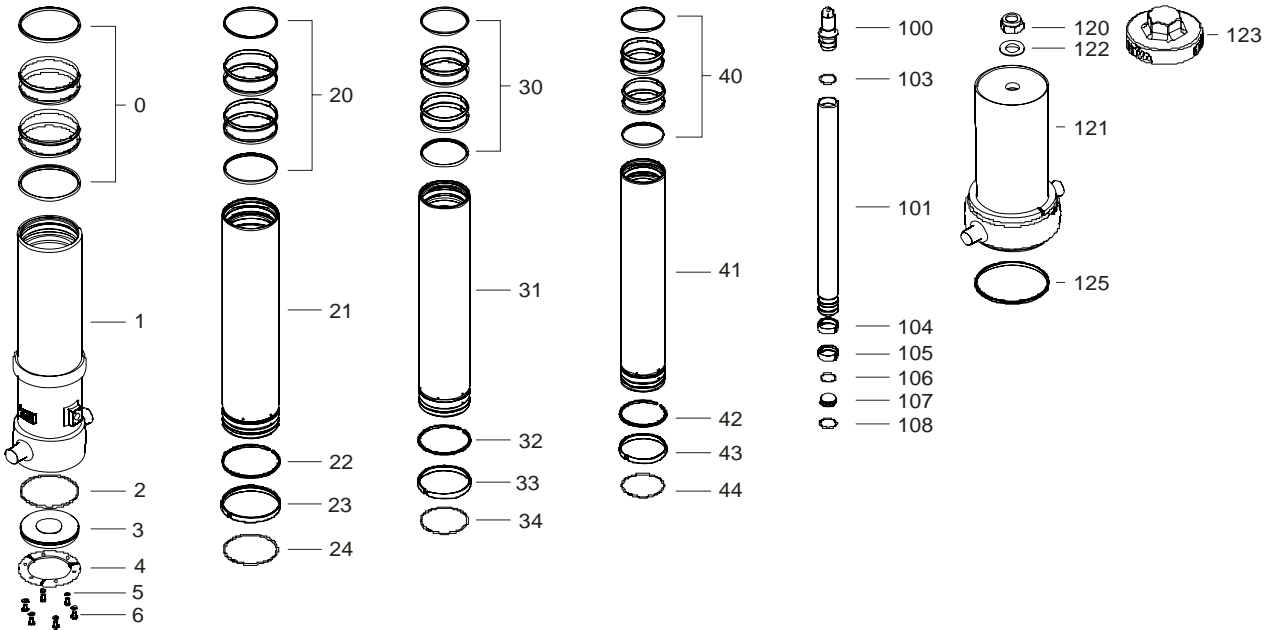

## Spare part list

Pos	Part no.	Description	Qty.
0	71802169 K	PACKSET 169	01
1	72506440R1145	BASE 169-1479-4/4SAE-190-C242	01
2	71870035 K	SEAL BOTTOM PLATE 169	01
3	71821169	BOTTOM PLATE 169	01
4	71820169	LOCKING PLATE 169	03
5	01732559 K	SPRING WASHER M8 SET	01
6	01732055 K	BOLT M8 X 1.25 X 20 SET	01
20	71802149 K	PACKSET 149	01
21	72605440	STAGE 149-1440	01
22	71811149 K	STOPRING OUTER 149	01
23	71807149 K	SLIDER 149	01
24	71812149 K	LIFTRING 149	01
30	71802129 K	PACKSET 129	01
31	72604440	STAGE 129-1440	01
32		NOT APPLICABLE	
33	71807129 K	SLIDER 129 (2 X 1/2)	02
34	71812129 K	LIFTRING 129	01

## Spare part list

Pos	Part no.	Description	Qty.
40	71802110 K	PACKSET 110	01
41	72603440	STAGE 110-1440	01
42		NOT APPLICABLE	
43	71807110 K	SLIDER 110 (2 X 1/2)	02
44	71812110 K	LIFTRING 110	01
100	71831091	PISTON HEAD 091 MACHINED	01
101	72402441	PISTON S 091-1445-HC	01
103	71870115 K	O-RING PISTON TOP 091	01
104	71807091 K	SLIDER 091 (2 X 1/2)	01
105	71807091 K	SLIDER 091 (2 X 1/2)	01
106	71870215	O-RING PISTON BOTTOM 091	01
107	71822091	BOTTOM PLATE PISTON 091	01
108	71814091	SNAPRING FOR PISTON 091	01
120	01702907	TOPNUT NYLOC M48x3 DIN 985 ZP	01
121	71706480	COVER 242-1245 PIN60	01
122	01702956	WASHER M48 DIN 125B ZP	01
123	01702972	DUST COVER FOR COVER 242 YELLOW CO	01
125	01791941	O-RING COVER D242	01

## Seal kit complete:

Part no.	Description
71901540 K	Seal kit complete: consists of all packsets with packset grease and O-rings